

AeroLogic®

AIR DUCT DISINFECTION

Models AERO-8, AERO-12, AERO-14, AERO-16, AERO-18,
AERO-20, AERO-24, AERO-26, AERO-32 & AERO-44



Installation, Operation & Maintenance

ATLANTIC  **ULTRAVIOLET**
CORPORATION®

375 Marcus Boulevard • Hauppauge, NY 11788 • USA
631.273.0500 • Fax: 631.273.0771
e-mail: info@ultraviolet.com

Extensive Product Information Available at:

ultraviolet.com

Document No. 98-1389B1 • February 2011 • ©2009-2011 Atlantic Ultraviolet Corporation®

Owner's Manual

TABLE OF CONTENTS

SAFETY WARNINGS	3
SAFETY INSTRUCTIONS	3
PRODUCT APPLICATION	4
CONSTRUCTION	4
PRINCIPLE OF OPERATION	4
LIMITATIONS	4
UNPACKING	5
INSTALLATION	6
UNIT PLACEMENT.....	6
DIMENSIONAL DATA.....	7-8
<i>AERO UNIT</i>	7
<i>SIGHT GLASS</i>	8
SIGHT GLASS LOCATION & INSTALLATION	8
MOUNTING TEMPLATES - FULL SCALE.....	9
UNIT, LAMP AND QUARTZ SLEEVE INSTALLATION, REPLACEMENT OR CLEANING	11
PRECAUTIONS	12
MAINTENANCE	12
BREAKAGE	12
DISPOSAL OF MERCURY ADDED LAMP.....	12
OPTIONAL ACCESSORIES	12
TROUBLESHOOTING	13
TECHNICAL SPECIFICATIONS	13
REPLACEMENT PARTS	14-15
USER ASSISTANCE	16
WARRANTY	16
PATENT NOTICE.....	16

These instructions generally describe the installation, operation and maintenance of the **AeroLogic®** Air Duct Disinfection Units . Questions that are not specifically answerable by these instructions should be directed to the factory. Atlantic Ultraviolet Corporation takes all possible precautions when packaging equipment to prevent damage. Carefully inspect and report all damages. Do not install damaged equipment. Follow all instructions on any labels or tags. Carefully inspect all packing materials before discarding to prevent the loss of accessories, mounting hardware, spare parts or instructions.

The information and recommendations contained in this publication are based upon data collected by the Atlantic Ultraviolet Corporation® and are believed to be correct. However, no guarantee or warranty of any kind, expressed or implied, is made with respect to the information contained herein. Specifications and information are subject to change without notice.



SAFETY WARNINGS

- All personnel should be alerted to the potential hazards indicated by the product safety labeling on this unit.
- The following conventions are used to indicate and classify precautions in this manual and on product safety labeling. Failure to observe precautions could result in injury to people or damage to property.



This is the safety alert symbol. It is used to alert you to potential personal injury hazards. Obey all safety messages that follow this symbol to avoid possible injury or death.



This symbol/pictorial is used to identify an **ELECTRICAL SHOCK** or **ELECTROCUTION** hazard.

DANGER

Danger indicates an **IMMINENTLY** hazardous situation, which, if not avoided, **WILL** result in death or serious injury.



This symbol/pictorial is used to identify an **ULTRAVIOLET LIGHT** hazard.

WARNING

Warning indicates a **POTENTIALLY** hazardous situation, which, if not avoided, **COULD** result in death or serious injury.



This symbol/pictorial is used to identify the need to wear approved ultraviolet resistant face shield.

CAUTION

Caution indicates a **POTENTIALLY** hazardous situation, which, if not avoided, **MAY** result in minor or moderate injury.



This symbol/pictorial is used to identify the need to wear approved ultraviolet resistant eyewear.

CAUTION

Caution used without the safety alert symbol indicates a potentially hazardous situation, which, if not avoided, may result in property damage.



This symbol/pictorial is used to identify the need to wear protective gloves.

- Product safety labels should be periodically inspected and cleaned, as necessary, to maintain good legibility. Always replace illegible safety labels. Contact factory to obtain replacement safety labels.



SAFETY INSTRUCTIONS

WARNING: To guard against injury, basic safety precautions should be observed, including the following:

1. Read and follow **ALL** safety instructions.



 **WARNING:** Avoid exposure to direct or strongly reflected germicidal ultraviolet rays. Germicidal ultraviolet rays are harmful to the eyes and skin.

2. Intended for indoor use only.
3. Do not alter the construction or design.
4. Do not use this unit for other than its intended purpose, as described in this manual.
5. Do not mount under any source of moisture or condensation, such as humidifiers, cooling coils, etc.
6. Do not mount this unit so that ultraviolet light is visible after installation.
7. **CAUTION:** Germicidal ultraviolet rays may break down plastic, rubber or other non-metallic materials, with inadequate resistance to ultraviolet. Shield all plastic, rubber or other non-metallic parts such as; plastic drain pans, wire insulation, flex ducts, humidifiers, filters, etc. which may be exposed to direct or reflected germicidal ultraviolet rays.
8. Do not remove any labels or devices.
9.  **CAUTION:** Do not operate without proper electrical ground.
10. Do not operate the unit if there is visible or suspected damage to the unit or, if applicable, there is damage to power cord and/or plug.
11. Utility power supplied, to the unit, **MUST** match power requirements listed on the unit label.
12.  **WARNING:** Always disconnect power to the unit before performing any service or maintenance.
13. Read and follow all notices and warnings on the unit.
14. **SAVE THESE INSTRUCTIONS.**

PRODUCT APPLICATION

CONSTRUCTION

The **AeroLogic**[®] Air Duct Disinfection Unit consists of:

- Quartz sleeve to protect and insulate the germicidal ultraviolet lamp. The quartz sleeve protects the ultraviolet lamp from deposits of dirt and/or dust while insulating it from low air temperatures and the cooling affects of high air velocities in the air duct.
- Germicidal ultraviolet lamp, which delivers ultraviolet energy at the specific wavelength of 254 nanometers (**nm**). This wavelength is highly effective against microbes including: virus, bacteria, and mold spores.
- Electronic ballast (120v 50/60Hz or 220v 50/60Hz version available).
- All electronics and wiring are housed in an enclosure constructed of lightweight, anodized aluminum alloy. The hard coat anodize offers an increased surface hardness, for durability, and corrosion resistance similar to that of stainless steel.
- Water resistant power cord, rated for indoor/outdoor use (on 120v units)
- Liquid-tight cord grip form a “drip-proof” assembly.

PRINCIPLE OF OPERATION

The **AeroLogic**[®] line of Air Duct Disinfection Units have been carefully conceived to provide germicidal ultraviolet exposure for air stream and surface disinfection. The dosage, as it applies to ultraviolet disinfection, is a function of time, and the intensity, of ultraviolet radiation, to which the air stream and surface is exposed. The exposure time, in seconds, is the total time it takes the air to move through the ultraviolet field, produced by the germicidal lamp(s). Exposure time is related to the airflow rate; the higher the airflow, the lower the exposure time or the lower the airflow, the higher the exposure time. The UV intensity is the amount of energy, per unit time, emitted by the germicidal lamp.

LIMITATIONS

- The **AeroLogic**[®] requires professional installation so all wiring complies with applicable state, local and national electrical and mechanical codes.
- **AeroLogic**[®] requires knowledgeable planning for: location, installation, and supervision to prevent ultraviolet exposure of personnel.
- Overexposure to germicidal ultraviolet rays will result in the irritation of the eyes and reddening of the skin. For that reason, it is of the utmost importance that your ultraviolet application be carefully planned and implemented so as to avoid exposure, of personnel, to direct or reflected ultraviolet rays.
- The American Conference of Governmental Industrial Hygienists (**ACGIH**) has established a Threshold Limit Value (**TLV**) for occupational exposure to radiant ultraviolet energy.
- Currently the ultraviolet radiant exposure incident for unprotected eyes or skin should not exceed 0.2 microwatts per square centimeter ($\mu\text{W}/\text{cm}^2$) at 254 nanometers (**nm**) for an eight (8) hour period.
- Safety and maintenance procedures should be implemented to prevent accidental exposure of personnel, who maintain the HVAC system. All work performed on the HVAC system must be monitored to insure that it does not adversely impact the safety or effectiveness of the installation

UNPACKING

- Remove the **AeroLogic®** Air Duct Disinfection Unit from its shipping carton.
- Atlantic Ultraviolet Corporation takes all possible precautions when packaging this unit to prevent damage. Carefully inspect the unit, power cord and plug for damage, report all damage immediately. Do not assemble or operate if there is any damage, visible or suspected.
- The germicidal lamp and quartz sleeve, o-ring and Teflon® washer are packed separately, to ensure maximum protection. Keep these items aside until ready for installation.
- Carefully inspect all packing materials to prevent the loss of accessories, mounting hardware, spare parts or instructions.
- Do not discard packing materials until unit is assembled and check out is complete.

AeroLogic® AERO Kit includes:

- 1 - AERO Unit with Attached Line Cord
- 1 - Duct Mounting Hub with Gasket
- 4 - No. 8-18 x 3/4" Self-Drilling Screws
- 1 - Germicidal Ultraviolet Lamp
- 1 - Quartz Sleeve, O-ring and Teflon® Washer
- 1 - 1 inch Sight Glass Assembly
with 4 - No. 8-18 x 3/8" Self-Drilling Screws
- 1 - Operating Instructions
- 2 - Duct Warning Labels

Duct Warning Label (2 - supplied)

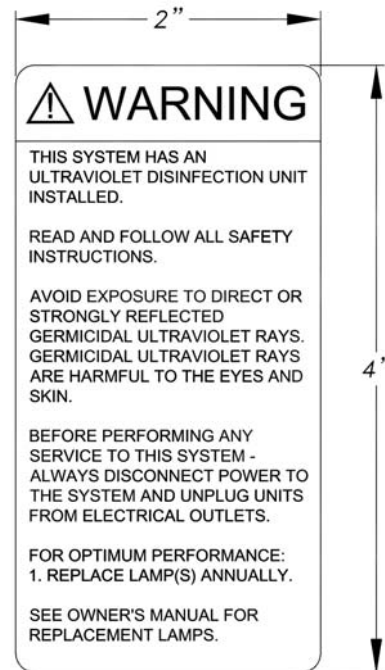

INSTALLATION

UNIT PLACEMENT

Proper unit placement is essential. To ensure safe and effective operation, the location should:

- Have enough duct width to mount unit with lamp perpendicular to airflow, with the longest duct length for increased exposure time.
- Be on the supply air plenum, LOCATION A (preferred), or on the return air plenum, LOCATION B (alternate). See **Figure 1- Unit Replacement**.
- Be able to support the weight of the **AeroLogic®** unit. If the duct construction does seem capable of supporting the weight, the duct must be re-enforced, to support the weight, before installing.
- Have a properly grounded, electrical outlet within reach of the unit's power supply cord.
- Not be mounted under any source of moisture or condensation, such as humidifiers, cooling coils, etc.
- Not be mounted near any duct openings, joints, seams, etc. If necessary, seal all openings, joints, seams, etc. using aluminum tape or equivalent ultraviolet resistant material.
- Prevent exposure of any plastic, rubber or other non-metallic materials, with inadequate resistance to ultraviolet, such as; plastic drain pans, wiring insulation, flex ducts, humidifiers, filters etc. If necessary, shield all plastic, rubber or other non-metallic parts using aluminum tape, conduit, sheet metal or equivalent ultraviolet resistant material.
- Be free of any components that would be damaged by or interfere with the installation.
- Be easily accessible for viewing lamp operation through the sight glass assembly.
- Be easily accessible and allow enough clearance for routine cleaning or maintenance.
- Be downstream from air filters. Dust particles will reduce the effectiveness of the unit.

Figure 1 - Unit Placement

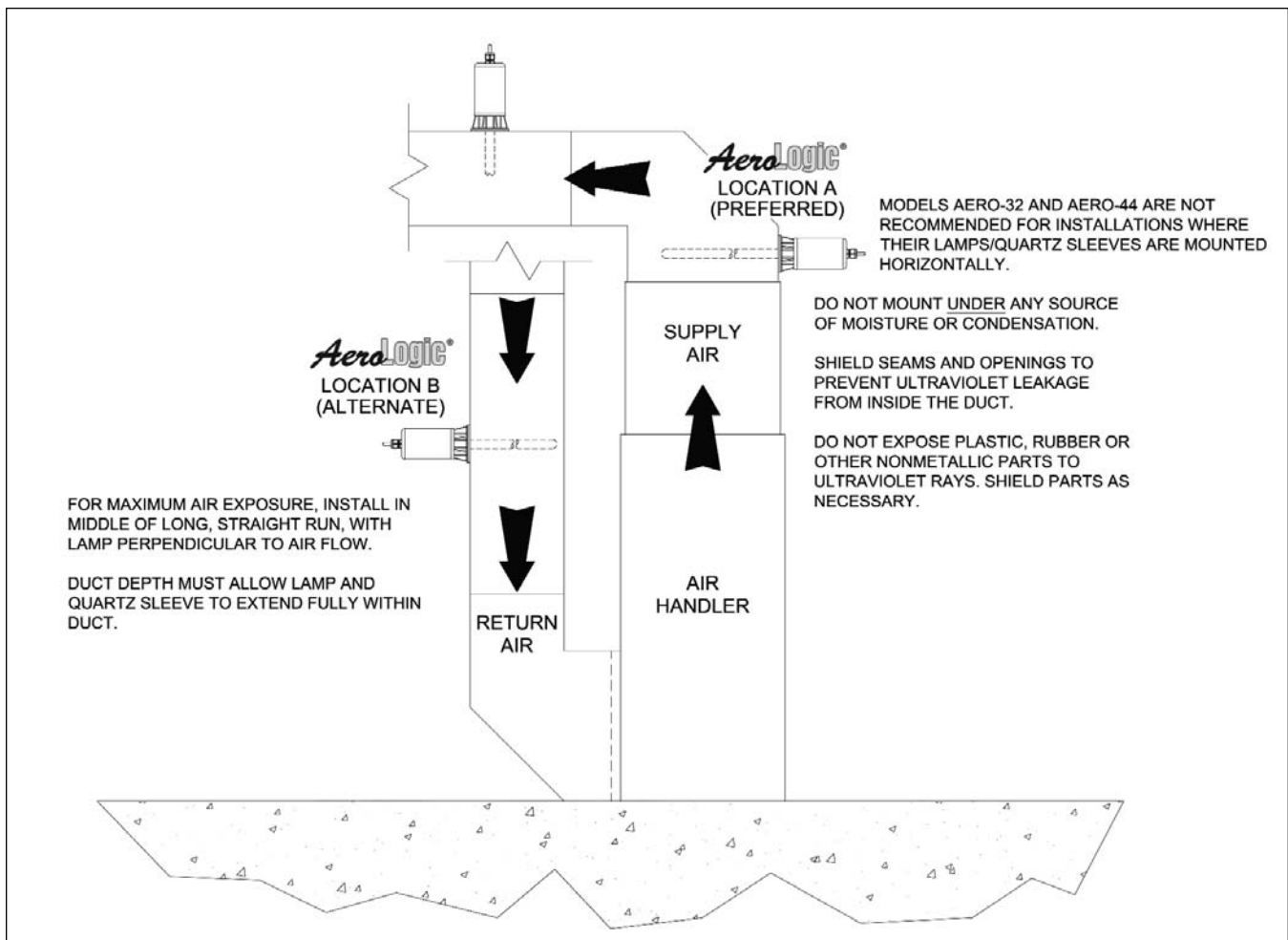
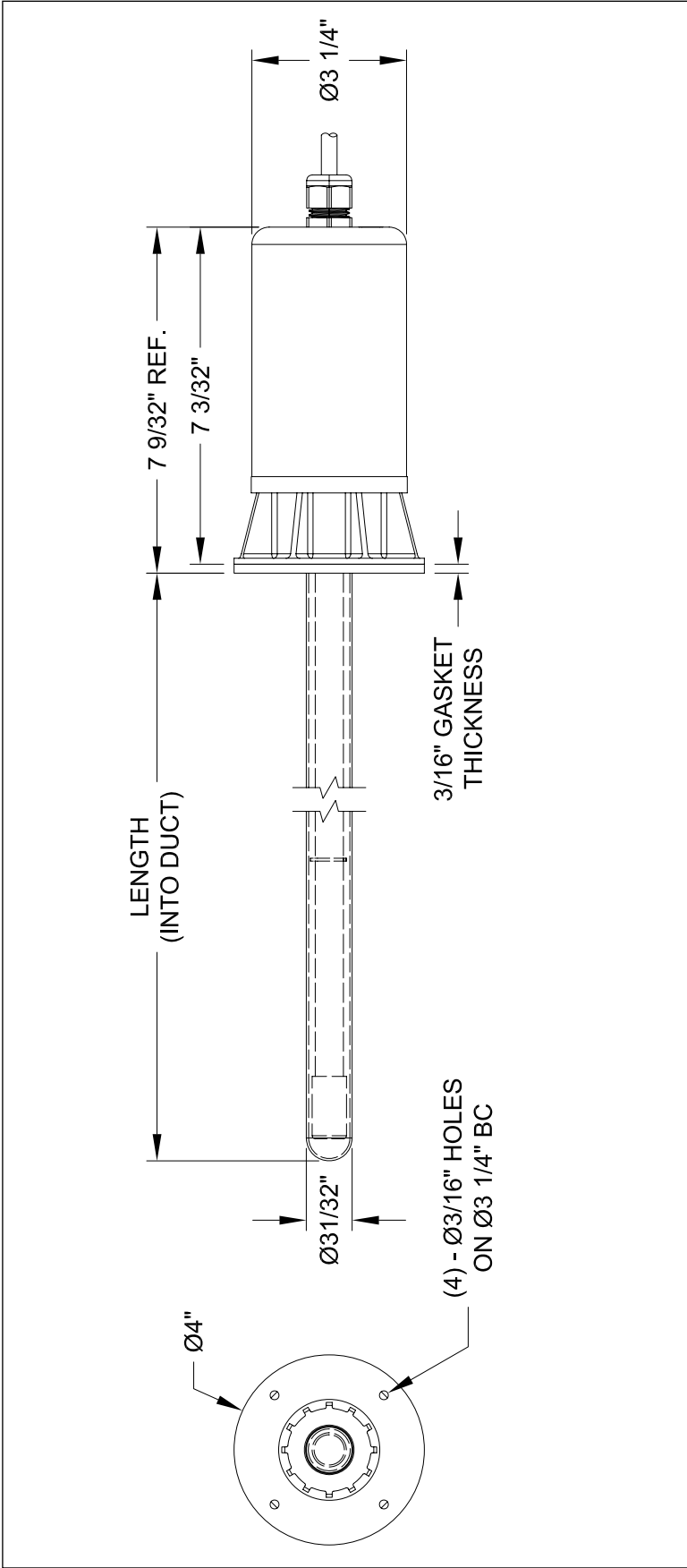
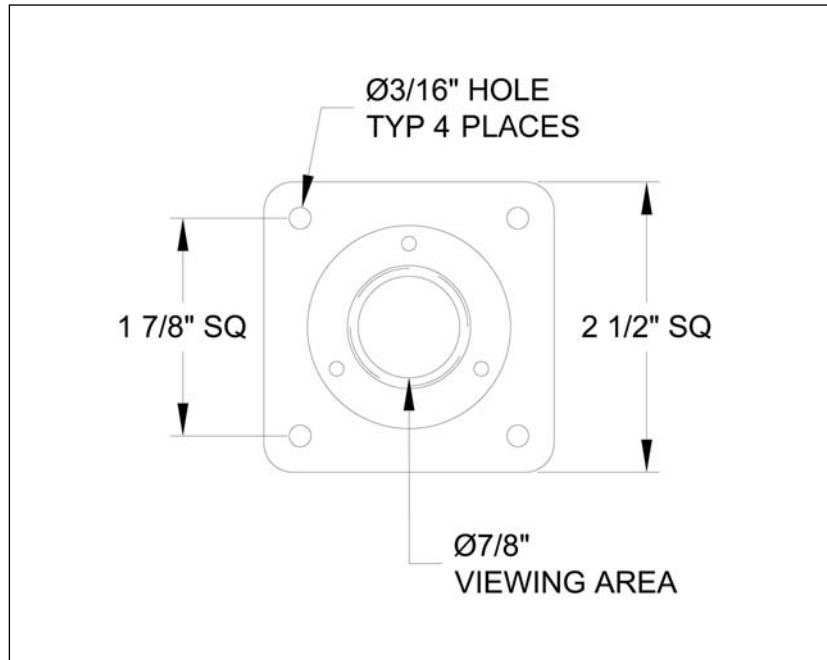

Figure 2 - Dimensional Data AERO



DIMENSIONAL DATA - SIGHT GLASS

Figure 3 - Sight Glass Dimensional Data



SIGHT GLASS LOCATION & INSTALLATION

The **AeroLogic®** Air Duct Disinfection Unit comes standard with a 1-inch Sight Glass Assembly, which is installed separately. The ultraviolet blocking, sight glass allows for visual inspection of the lamps, without the need to remove the unit from the duct.

1. Select a suitable location near the **AeroLogic®** installation.
2. Using the Sight Glass Mounting Cutout (See Figure 6 on page 9) mark the centers of the mounting holes and clearance hole for the sight glass.



CAUTION: Mechanical hazard. Duct sheet metal has sharp edges.
Wear protective gloves when working on or around duct sheet metal.

3. Cut out the opening for the sight glass. Remove burrs and sharp edges where possible.
4. Using the supplied No. 8-18 x 3/8" long hardware, mount the sight glass assembly to the duct.

Figure 5 - AERO Mounting Template - Full Scale

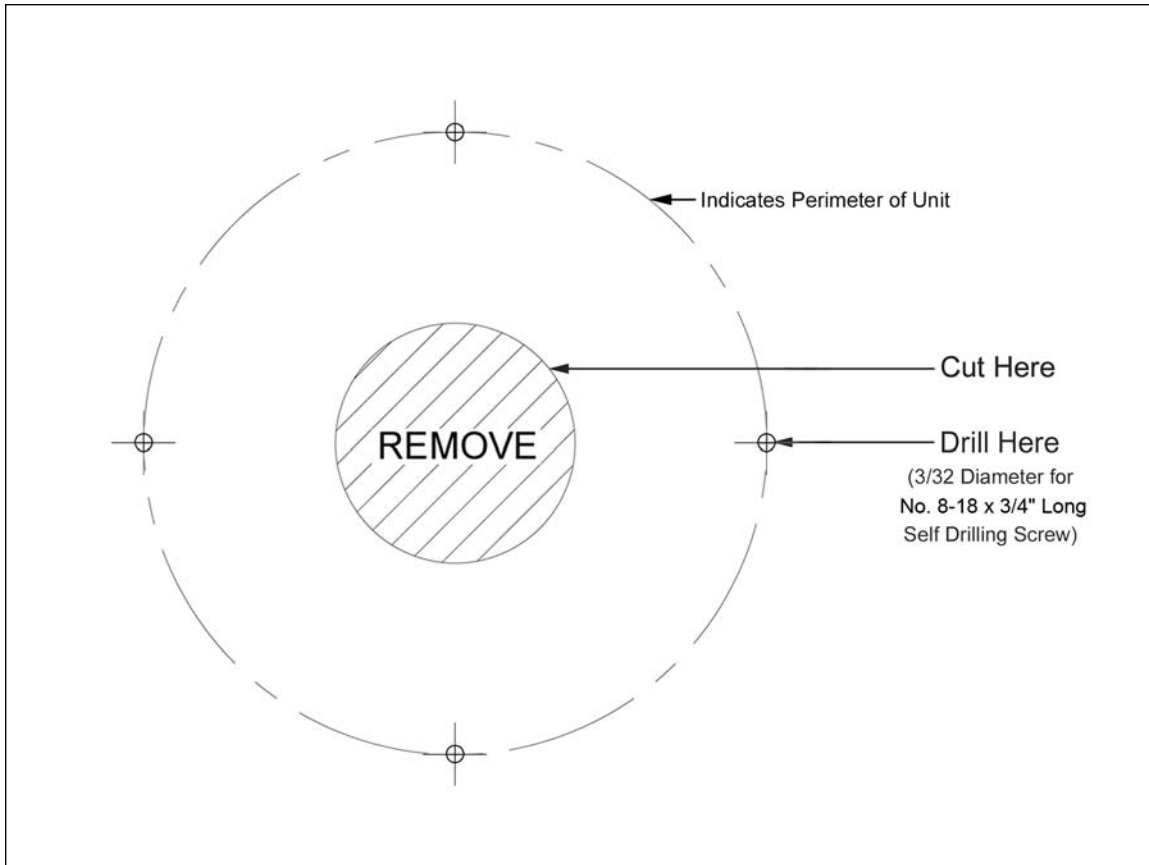
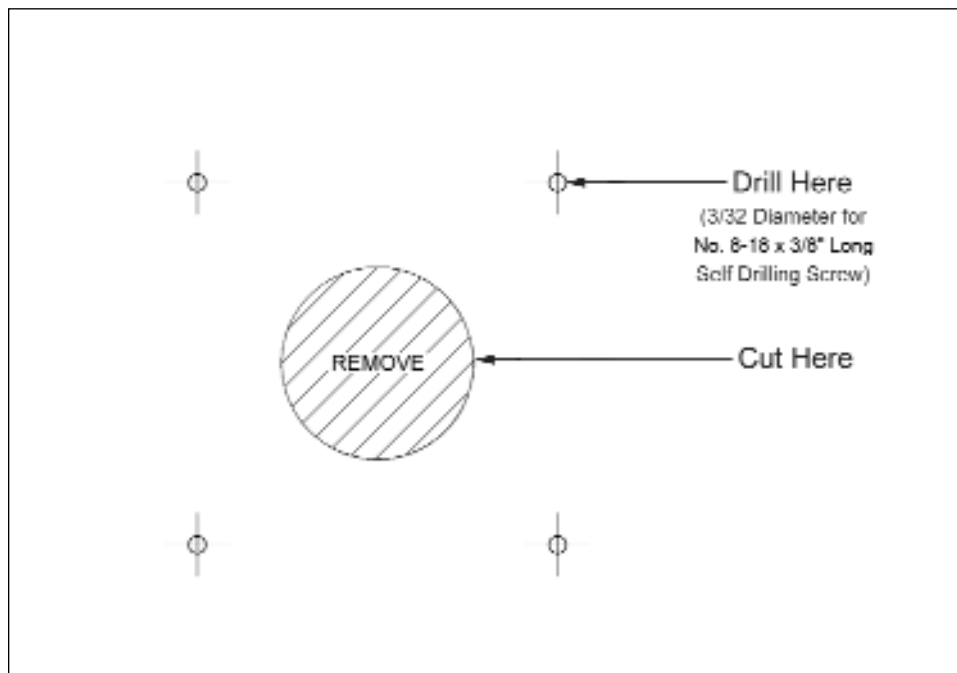

Figure 6 - Sight Glass Mounting Template - Full Scale



(This page is intentionally blank)

UNIT, LAMP AND QUARTZ SLEEVE INSTALLATION, REPLACEMENT OR CLEANING

▲ WARNING: Always disconnect power to the unit before performing any service or maintenance.

▲ CAUTION: Ultraviolet lamp and quartz sleeve are easily damaged and may cause injury if broken.

Exercise care when handling.

1. Disconnect power to the HVAC system.
2. Using mounting hub, mark the centers (locations) of the four (4) 3/32" pilot holes and the 1 1/4" center hole. Also see "Figure 5 - AERO Mounting Cutout" on page 9.



▲ CAUTION: Mechanical hazard. Duct sheet metal has sharp edges. Wear protective gloves when working on or around duct sheet metal.

3. Drill the appropriate holes as indicated on the mounting pattern. Remove burrs and sharp edges where possible.
4. Install the gasket and mounting hub to the duct using the supplied No. 8-18 x 3/4" mounting hardware.
5. **Install lamp.** The lamp socket is located inside the threaded end of the AeroLogic® base. To install; line up lamp pins with lamp socket. Carefully press lamp pins into the socket until lamp is seated against the socket.
6. Moisten a clean, lint-free cloth with denatured alcohol and wipe the lamp.

Figure 4 - Lamp & Quartz Sleeve Installation

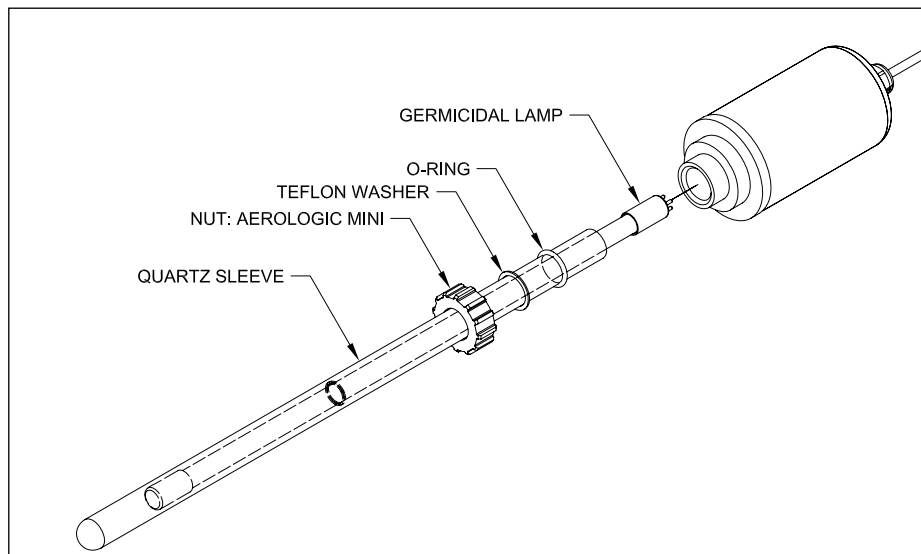

7. **Install quartz sleeve.**
 - a. Place o-ring approximately 3/4" to 1" from the open end of the quartz sleeve.
 - b. Carefully slide the quartz sleeve over the lamp, into the threaded base. The quartz sleeve will rest against a shoulder in the mounting base. Slide the o-ring down until it is seated against the angled face of the base.
 - c. Slide the Teflon® washer over the quartz sleeve until it is resting against the o-ring.
 - d. Slide the nut over the quartz sleeve and tighten firmly (by hand only). **Do not use hand tools!** Tightening with hand tools is likely to cause quartz sleeve to break.
8. Moisten a clean, lint-free cloth with denatured alcohol and wipe the quartz sleeve.
9. Fit AeroLogic® to the mounting hub, and tighten until secure.
10. Plug AeroLogic® into properly grounded, electrical outlet.
11. Restore power to the HVAC system.



▲ WARNING: Avoid exposure to direct or strongly reflected germicidal ultraviolet rays. Germicidal ultraviolet rays are harmful to the eyes and skin.

12. Verify operation by viewing lamp, use of personal protection equipment is required. If the unit is not operating properly, go to "Troubleshooting" section on page 13.
13. While wearing protective eye wear, inspect HVAC system for any ultraviolet light leakage. No ultraviolet light should be visible from any duct opening, joint, seam, etc. The installation can also be inspected using a sensitive ultraviolet meter, to insure that the ultraviolet radiant exposure of personnel is within acceptable limits. If necessary, seal any openings, joints, seams, etc. using aluminum tape or equivalent ultraviolet resistant material. (See "Zenith™ Ultraviolet Meter" in the "Optional Accessories" section on page 12.)

PRECAUTIONS

- The **AeroLogic**[®] must be disconnected from power whenever anyone works on the HVAC system. Anyone who works in and around the system should be briefed on the precautions to be observed.
- The HVAC system should be re-inspected for any ultraviolet light leakage whenever any maintenance or modifications are performed.
- If there are any doubts or concerns about the safety or the effectiveness of the installation, or if a sensitive ultraviolet meter is required, please contact our application specialists.

MAINTENANCE

- The **AeroLogic**[®] is designed to operate with a minimal amount of maintenance.
- A regular cleaning cycle of the germicidal lamp and sight glass should be established, and carefully maintained, based on inspection and experience. The frequency of cleaning will vary with the conditions surrounding each installation. It is recommended that the ultraviolet lamp(s) be cleaned at least once every three (3) months.
- The germicidal ultraviolet lamp used in the **AeroLogic**[®] have a manufacturer's rated average effective life of 10,000 hours. Lamps may operate longer than their rated effective life, but the reduction in ultraviolet output will make it impractical to use past the manufacturer's rated life. For maximum efficiency lamp replacement is recommended every 10,000 hours of operation or about one (1) year of continuous use.
- Unless lamp replacement is due to failure or breakage, it is recommended that all lamps be replaced at the same time.
- For proper germicidal lamp and/or quartz sleeve replacement and cleaning procedure see “**Lamp Installation, Replacement Or Cleaning**” on page 11.

▲ WARNING: Always disconnect power to the unit before performing any service or maintenance.

BREAKAGE

▲ CAUTION: Broken Quartz is SHARP.

Wear protective gloves when handling broken ultraviolet lamps or quartz sleeves.



In the event of breakage, **DO NOT** use a household vacuum cleaner to pick up quartz fragments. Sweep up debris into a plastic bag and dispose of properly.

DISPOSAL OF MERCURY ADDED LAMPS

Germicidal ultraviolet lamps, like standard fluorescent lamps contain small amounts of mercury. Mercury added lamps should not be placed in the trash. Dispose of properly.

For further information regarding the disposal and recycling of lamps containing mercury, along with Federal and State requirements visit <http://www.lamprecycle.org>. Product Data Sheets for germicidal ultraviolet lamps can be found in the “PDF Library for **STER-L-RAY**[®] Germicidal Ultraviolet Lamps” section of <http://www.ultraviolet.com>.

OPTIONAL ACCESSORIES

1. The **Zenith**[™] **Ultraviolet Meter** is a sensitive, hand-held, ultraviolet meter that can be used to:
 - Survey installations to ensure that the germicidal ultraviolet radiant exposure, of personnel within the treated area, is within acceptable limits. The **Zenith**[™] **Ultraviolet Meter** provides accurate and easy-to-read levels of intensity that may be interpreted by anyone - not just engineers.
 - Check the intensity of aging ultraviolet lampsThe **Zenith**[™] Part No. 30-0081-R is the recommended meter for this application.
2. **Observation Port Sight Glass Assembly - Additional**
A Sight Glass Assembly allows for visual inspection of the lamp, without the need to remove the unit from the duct. 1 - 1 inch Sight Glass Assembly is included with each unit. If needed, additional Sight Glass Assemblies are available in 1 and 2 inch diameters.

TROUBLESHOOTING

⚠ WARNING: Always disconnect power to the unit before performing any service or maintenance.



Use **personal protection equipment**, such as gloves; long sleeves with no gaps between cuffs and gloves, and ultraviolet resistant face shield, if troubleshooting **AeroLogic®**.

- IMPORTANT:** This unit is to be serviced **ONLY** by qualified, and appropriately licensed, personnel.

Table 1 - Troubleshooting

Problem	Possible Cause	Corrective Action
Unit not operating.	No electrical power...	Verify that the unit is connected to a live power source.
Germicidal lamp not operating.	Germicidal lamp not properly seated...	Confirm connection of lamp and lamp socket, make sure connection is tight and lamp is making full contact with lamp socket.
	Germicidal lamp faulty...	Replace lamp.
	Ballast not functioning...	Replace ballast.

TECHNICAL SPECIFICATIONS

Table 2 - Technical Specifications

Model No:	Current (A)		Lamp Model:	Lamp Power	Ultraviolet Output: ①	Length: (into duct)
	120v	220v				
AERO-8	.12A	.10A	05-1119-R	10W	2.3W	7 5/32-in.
AERO-12	.16A	.16A	05-1366-R	14W	3.7W	10 7/64-in.
AERO-14	.21A	.17A	05-0218-R	17W	5.8W	14-in.
AERO-16	.22A	.19A	05-1370-R	21W	6.4W	15 31/32-in.
AERO-18	.23A	.20A	05-1523-R	22W	6.9W	17 1/32-in.
AERO-20	.25A	.23A	05-0117-R	25W	8.5W	20-in.
AERO-24	.27A	.26A	05-0097-R	29W	9.7W	23 7/32-in.
AERO-26	.30A	.29A	05-0219-R	32W	11.2W	26-in.
AERO-32	.32A	.36A	05-1382-R	39W	13.8W	32-in.
AERO-44	.50A	.46A	05-0197-R	50W	19.3W	44-in.

① Ultraviolet output at 254nm at 100 hours and 80°F (approximate).

All specifications, dimensional data, etc. are approximate and subject to change without notice.

REPLACEMENT PARTS

Figure 7 - Exploded View

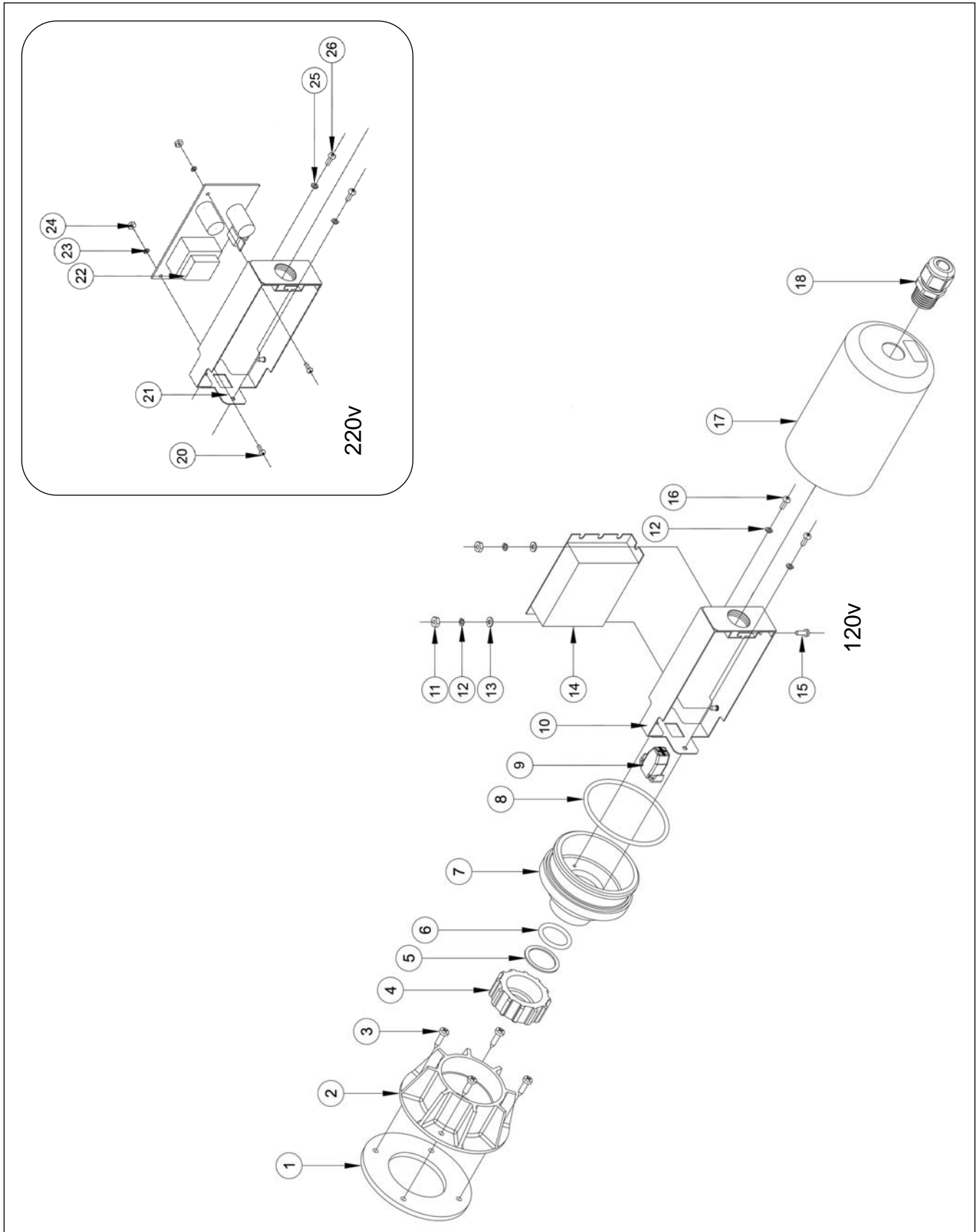

REPLACEMENT PARTS

Table 3 - Replacement Parts

ITEM NO.	DESCRIPTION	QTY	PART NO.
1	Gasket - Mounting Hub	1	40-6018A
2	Mounting Hub:	1	40-6005A
3	Screw: 8-18x3/4" Pan Head	4	50-0400
4	Nut: AeroLogic® Mini	1	40-6002A2
5	Teflon® Washer	1	00-0229A
6	O-Ring	1	00-0116
7	Base: AeroLogic® Mini	1	40-6001A2
8	O-Ring	1	00-2233
9	Lamp Socket: 4 Pin Snap-In	1	35-1124A
10	Chassis Assembly: 120v	1	40-6028A
11	Nut: 6-32 Finish Hex	2	50-1178
12	Washer: No. 6 Lock	4	50-1393
13	Washer: No. 6 Flat	2	50-1402
14	Ballast: 120v	1	10-0150
15	Screw: 6-32 x 1/2" Philips	1	50-0155
16	Screw: 6-32 x 3/8" Philips	2	50-0061
17	Cover AeroLogic® Mini	1	40-6015
18	Strain Relief: Liquid Tight	1	35-0052
19	Line Cord: 120v	1	35-1046
	Line Cord: 220-240v	1	35-1452
20	Screw: 4-40 x 1/4" Philips	2	50-1006
21	Chassis Assembly: 220v	1	40-6042A
22	Ballast: 220v	1	35-0219A-R
23	Washer: No. 4 Lock	2	50-0017
24	Nut: 4-40 Finish Hex	2	50-1186
25	Washer: No. 6 Lock	2	50-1393
26	Screw: 6-32 x 3/8" Philips	2	50-0061

Other replacement parts are available. Consult the factory with specific requirements.

Table 4 - Replacement - Lamps - Quartz Sleeves

GERMICIDAL MODEL	LAMP	QUARTZ SLEEVE
AERO-8	05-1119-R	15-6101A
AERO-12	05-1366-R	15-6102A
AERO-14	05-0218-R	15-6103A
AERO-16	05-1370-R	15-6104A
AERO-18	05-1523-R	15-6105A
AERO-20	05-0117-R	15-6106A
AERO-24	05-0097-R	15-6107A
AERO-26	05-0219-R	15-6108A
AERO-32	05-1382-R	15-6109A
AERO-44	05-0197-R	15-6110A

USER ASSISTANCE

Atlantic Ultraviolet Corporation makes every effort to ensure that the **AeroLogic®** Air Duct Disinfection Units are products of superior quality and workmanship. This manual describes the installation, operation and maintenance of the **AeroLogic®** Air Duct Disinfection Units.

Please read and become familiar with the contents of this manual before installing or using the **AeroLogic®**. If after reading the manual you still have questions, or concerns, regarding the installation or use of this system, contact our offices, weekdays between 8:30 am and 5:00 pm Eastern time, at:

Atlantic Ultraviolet Corporation
375 Marcus Boulevard
Hauppauge, New York, 11788

Tel: 631.273.0500
Fax: 631.273.0771

E-mail: info@ultraviolet.com
Website: www.ultraviolet.com

Please REGISTER your product immediately - you can do this in a number of ways. Go online to Ultraviolet.com and on the bottom left of each page either click on "Fill out Warranty Reg. Form on-line!" complete and hit submit or click on "Download a PDF of the Warranty Reg. card" which you can print, fill out and mail in. If you prefer to register over the telephone please call 631-273-0500.

Atlantic Ultraviolet Corporation takes considerable care when packaging equipment to prevent damage. Carefully inspect and report all damage. **Do not** install damaged equipment. Follow all instructions in this manual and on any labels or tags. Carefully inspect all packing materials before discarding to prevent the loss of accessories, mounting hardware, spare parts or instructions.

For your convenience, record the following information below. The model and serial number can be found on a label located on the **AeroLogic®** Air Duct Disinfection Unit. Keep this manual, along with proof of purchase, handy when contacting our offices.

Purchased From:	Date:
Model:	Serial No.:

WARRANTY

We warrant that this product will be free from defects in material and workmanship for a period of one year from the date of shipment thereof or the product's total rated life, whichever first occurs. Within the warranty period we shall repair or replace such products, which are returned to us with shipping charges prepaid, and which are determined by us to be defective. This warranty will not apply to any product, which has been subjected to misuse, negligence, or accident; or misapplied; or modified; or repaired by unauthorized persons; or improperly installed.

The Buyer shall inspect the product promptly after receipt and shall notify us at our main office in writing of claims, including claims of breach of warranty, within thirty (30) days after the Buyer discovers or should have discovered the facts upon which the claim is based. Failure of the Buyer to give written notice of a claim within the time period shall be deemed to be a waiver of such claim.

The provisions of the above warranty are our sole obligation and exclude all other remedies or warranties, expressed or implied, including warranties of merchantability and fitness for a particular purpose, whether or not purposes or specifications are described herein. We further disclaim any responsibility whatsoever to the customer, or to any person, for injury to person, damage to, or loss of property or value caused by any product which has been subjected to misuse, negligence, accident; or modified or repaired by unauthorized persons; or improperly installed.

Under no circumstances shall the Company be liable for any incidental, consequential or special damages, losses or expenses arising from the contract for this product, or in connection with the use of, or inability to use, our product for any purpose whatsoever.

PATENT NOTICE

No attempt has been made to determine the patent status of applications illustrated or described in this publication. Inclusion in this publication of any design or method of use, which may be patented, is not to be construed as promoting or sanctioning unauthorized use.